

OSWAL
kiln seals



**Graphite-Based
Sealing Elements**

Global Leader in Cement Process Technology Since 1985

Since 1985, Oswal kiln seal has specialized in precision-engineered systems for the cement industry, focusing on process stability, material handling, and quality control. With deep domain expertise and a process-driven approach, the company delivers reliable solutions that enhance efficiency, reduce variability, and ensure consistent plant performance aligned with global standards.

Key Benefits

■
Industry
Leadership

■
Pioneering
Innovation

■
Maximise energy
efficiency

■
Optimise
performance

■
Safety and
Reliability

Graphite-Based Sealing Elements

In high-temperature kiln environments, sealing performance is fundamentally defined by material behavior under extreme thermal and mechanical stress.

Graphite-based sealing elements operate at the most demanding interfaces of the rotary kiln – where continuous rotation, elevated temperatures, abrasive dust exposure, and pressure variation coexist. In these zones, conventional materials degrade, lose dimensional stability, or generate excessive friction, leading to sealing failure and increased energy losses.

Graphite-based sealing elements operate at the most demanding interfaces of the rotary kiln – where continuous rotation, elevated temperatures, abrasive dust exposure, and pressure variation coexist. In these zones, conventional materials degrade, lose dimensional stability, or generate excessive friction, leading to sealing failure and increased energy losses.

Oswal Kiln Seal designs graphite-based sealing elements engineered for real operating conditions – not laboratory assumptions.

Through precision material selection, optimized geometry, and controlled pressure integration, these elements deliver consistent sealing performance across thermal cycles, ensuring stable combustion, controlled air ingress, and long-term operational reliability.

Key Advantages

- High thermal resistance under extreme operating temperatures
- Stable friction characteristics for continuous sliding contact
- Reduced false air ingress and improved sealing efficiency
- Long wear life under abrasive dust conditions
- Consistent performance across thermal cycles
- Reduced maintenance and extended replacement intervals

Material Engineering

Graphite is selected for its inherent performance characteristics:

- High-temperature resistance
- Stable dimensional behavior under thermal load
- Controlled and predictable friction coefficient
- Resistance to thermal shock
- Chemical inertness in harsh process environments

These properties ensure reliable performance where conventional materials fail.

Engineering Concept

Graphite sealing elements are designed to function as primary sealing interfaces in high-temperature zones.

The design approach focuses on:

- Maintaining continuous sealing contact
- Ensuring controlled pressure distribution
- Delivering stable friction behavior under dynamic movement

This enables consistent sealing performance under continuous rotation and thermal stress.

The Principle of Friction & Contact Stability

Critical requirements for graphite sealing:

- Controlled contact pressure
- Smooth sliding interface
- Uniform wear behavior
- Stable friction characteristics

The system ensures:

- Low friction variation over time
- Even wear distribution
- Continuous sealing integrity

Result: Reliable sealing performance with minimal degradation

Functional Role in Sealing Systems

- Primary sealing interface in high-temperature zones
- Continuous sealing contact under extreme heat
- Uniform pressure distribution across sealing surface
- Stable performance under abrasive dust exposure

Friction & Wear Control

- Precision surface finishing for smooth contact
- Controlled pressure to minimize friction losses
- Low friction variation across operating cycles
- Even wear distribution for extended service life

Thermal Stability

- Compatible with kiln shell expansion behavior
- Resistant to rapid temperature changes
- Maintains structural integrity under sustained heat
- Stable performance during heat-up and cool-down cycles

Structural Integration

Graphite sealing elements are integrated across multiple Oswal systems:

- Duplex Kiln Sealing Systems
- High-Temperature Radial Seals
- Axial Compensation Seals
- Kiln Inlet Sealing Systems
- Kiln Outlet Sealing Systems

Mounting geometry ensures:

- Secure positioning
- Uniform pressure distribution
- Stable sealing alignment

Draft & Process Impact

- Reduced false air ingress
- Improved combustion stability
- Enhanced thermal efficiency
- Reduced fuel consumption
- Lower ID fan load

Operational Advantages

- Extended sealing component lifespan
- Reduced maintenance frequency
- Stable sealing performance under harsh conditions
- Improved overall kiln reliability
- Lower lifecycle operating cost

Typical Applications

- Cement rotary kilns
- High-temperature clinker production systems
- Lime and mineral processing kilns



Problem vs Solution

The Challenge

- Material degradation under high temperature
- Friction instability and wear
- Loss of sealing integrity
- Frequent replacement cycles

Proven Industry Impact

- Improved sealing reliability in high-temperature zones
- Reduced operational interruptions
- Lower maintenance costs
- Enhanced process stability
- Increased system lifespan

Oswal Graphite Solution

- High-temperature resistant material
- Controlled friction behavior
- Durable and stable sealing interface

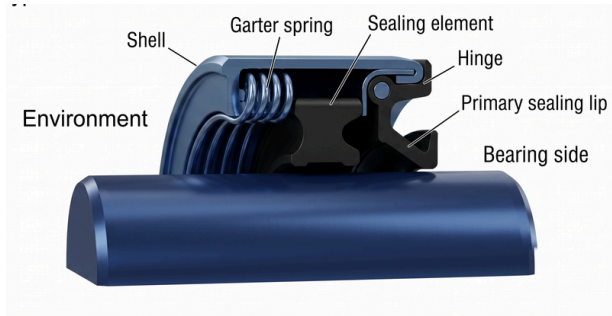

Engineering Outcome

High-temperature resistance.

Stable friction control.

Durable sealing performance in extreme thermal zones.

Graphite-Based Sealing Elements by Oswal Kiln Seal deliver long-term false air control in high-temperature clinker production environments — ensuring reliable performance, improved efficiency, and sustained operational stability.

The OE Graphite-Based Sealing Element System introduces a highly robust, low-maintenance architecture engineered with:

- High-Temperature Thermal Resilience & Stability
- Self-Lubricating, Low-Friction Composition
- Flexible 360° Conformity & Positive Sealing

SUSTAINABILITY IMPACT

Eliminating Thermal Loss at the Source

The **Oswal Kiln seal Graphite-Based Sealing** Elements create a highly dense, high-temperature resilient barrier that prevents heat dissipation, ensuring maximum thermal retention directly at the kiln interface.

Result:

- Significant reduction in specific fuel consumption by eliminating cold air ingress.
- Enhanced kiln thermal efficiency by securing a stable, continuous calcination environment.

Friction Reduction & Energy Optimization

Engineered with premium-grade, self-lubricating graphite blocks, the system is designed to provide maximum sealing performance with minimal mechanical drag against the kiln wear shell.

- Ultra-Low Sliding Friction
- Reduced Main Drive Power Load
- Minimized Structural Wear & Tear

Aligned with Global Sustainability Goals

Oswal sealing systems support global, industry-wide initiatives focused on sustainable resource management, industrial decarbonization, emission reduction, and automated operational excellence.

Emission Control & Environmental Performance

Maintaining a completely sealed process environment is critical for industrial workplace safety and stringent emission targets. The self-adjusting, overlapping design of the graphite elements ensures that fine kiln dust, raw meal, and hazardous gases are fully contained during active kiln rotation.

- Zero Kiln-Inlet Dust Leakage
- Fugitive Gas & Emission Elimination
- Safe, High-Temperature Material Containment

Process Stability & Clinker Quality

Consistent, uninterrupted contact across the entire kiln circumference directly translates into optimized plant resource management.

- Consistent Kiln Draft Profile
- Reduced Pyro-Process Fluctuations
- Minimized Thermal and Material Wastage



Zero thermal wastage. Absolute particulate containment. Optimized power consumption. Oswal Sealing Systems enable cleaner, more efficient, and resource-responsible plant operations.



OSWAL GROUP OF INDUSTRIES company

This brochure makes no offers, representations or warranties (express or implied), and information and data contained in this brochure are for general reference only and may change at any time.

www.oswalkilnseals.com

OSWAL
kiln seals